

KTZ-100X

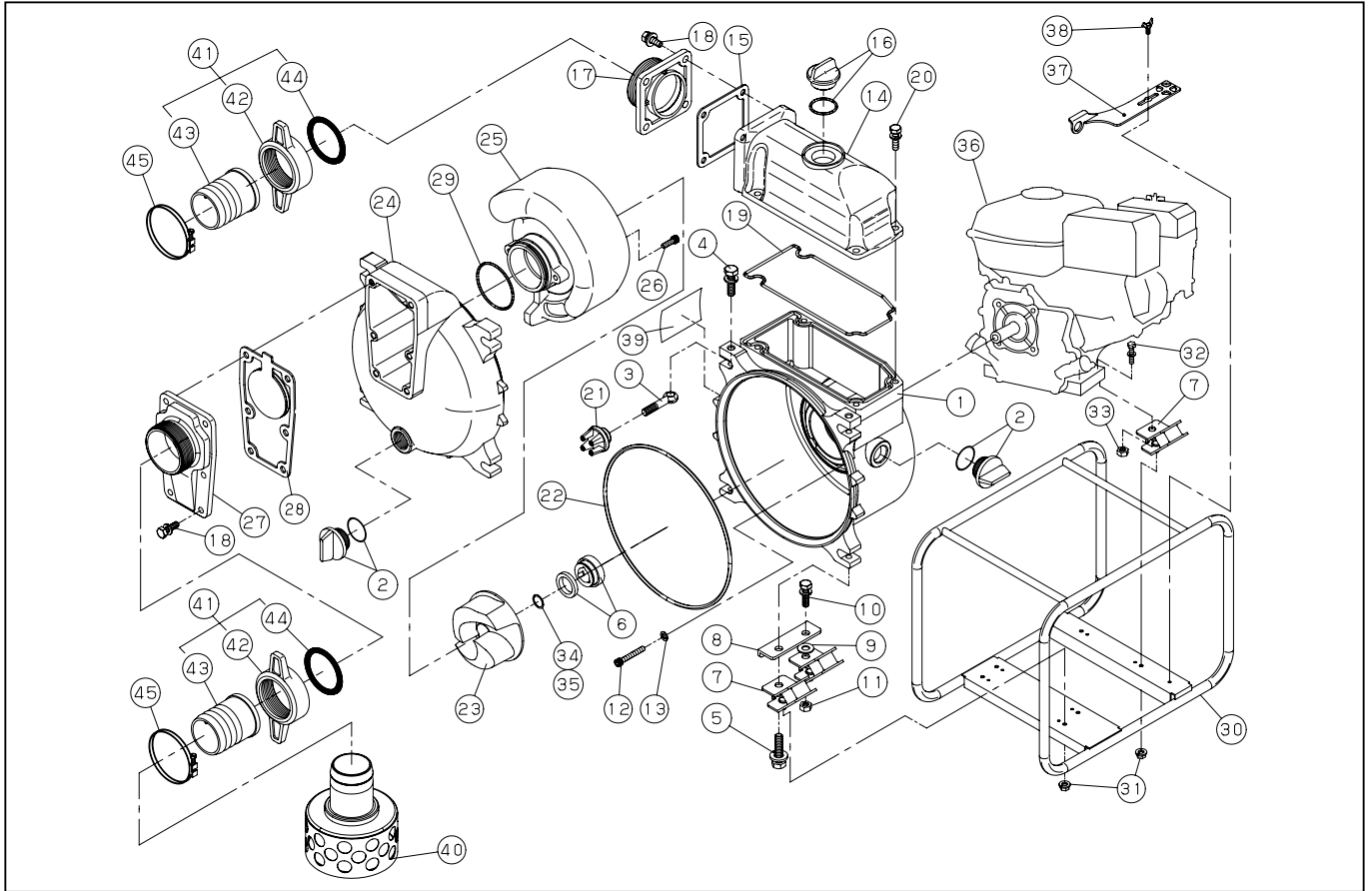

DWG No.012877804 MODEL : KTZ-100X FORM : KTZ-100X-BAF-0

| No. | PARTS CODE | PARTS NAME | QTY | MATERIAL | SIZE | REMARKS |
|-----|------------|-------------------------|-----|------------------|----------------|---------|
| 1 | 011615002 | PUMP BODY | 1 | ADC | | |
| 2 | 011807901 | 25A PLUG SET | 2 | | | |
| 3 | 011558001 | COVER BOLT | 4 | S35C | | |
| 4 | 743119083 | HEXAGON BOLT | 2 | SWRM | M12X45 | |
| 5 | 743119084 | HEXAGON BOLT | 2 | SWRM | M12X50 | |
| 6 | 011567802 | MECHANICAL SEAL | 1 | EH791-25 SICXSIC | | |
| 7 | 011617202 | CUSHION RUBBER | 6 | CR | | |
| 8 | 011627301 | RUBBER MOUNT | 2 | SPC | T4.5 | |
| 9 | 846211012 | WASHER | 2 | | 12 | |
| 10 | 743119076 | HEXAGON BOLT | 2 | SWRM | M12X25 | |
| 11 | 827419012 | HEXAGON NUT | 2 | SWRM | M12 | |
| 12 | 011649201 | HEXAGON SOCKET BOLT | 4 | SCM | M8X50 | |
| 13 | 011649302 | WASHER | 4 | ALUMINIUM | φ 8 | |
| 14 | 011614801 | DELIVERY HOUSING | 1 | ADC | | |
| 15 | 011075002 | DELIVERY FLANGE PACKING | 1 | CR | | |
| 16 | 011845001 | 32A PLUG SET | 1 | | | |
| 17 | 011618801 | SUCTION FLANGE | 1 | | | |
| 18 | 743119080 | HEXAGON BOLT | 10 | SWRM | M12X35 | |
| 19 | 011554801 | HEAD PACKING | 1 | NBR | | |
| 20 | 743119063 | BOLT | 4 | SWRM | M10X30 | |
| 21 | 011559001 | KNOB | 4 | | | |
| 22 | 011557901 | FRONT COVER PACKING | 1 | NBR | | |
| 23 | 011562602 | IMPELLER | 1 | HRFC | | |
| 24 | 011649002 | FRONT COVER(KOSHIN) | 1 | ADC | | |
| 25 | 011648801 | VOLUTE CASING | 1 | FCD | | |
| 26 | 011641901 | HEXAGON SOCKET BOLT | 3 | SUS | M8X35 | |
| 27 | 011626802 | SUCTION FLANGE | 1 | | | |
| 28 | 011826101 | CHECK VALVE | 1 | | | |
| 29 | 011627001 | O-RING | 1 | NBR | φ 104.5X φ 3.5 | |
| 30 | 011770201 | BASE SET | 1 | | | |

◆ Bare engine can not be supplied

KTZ-100X

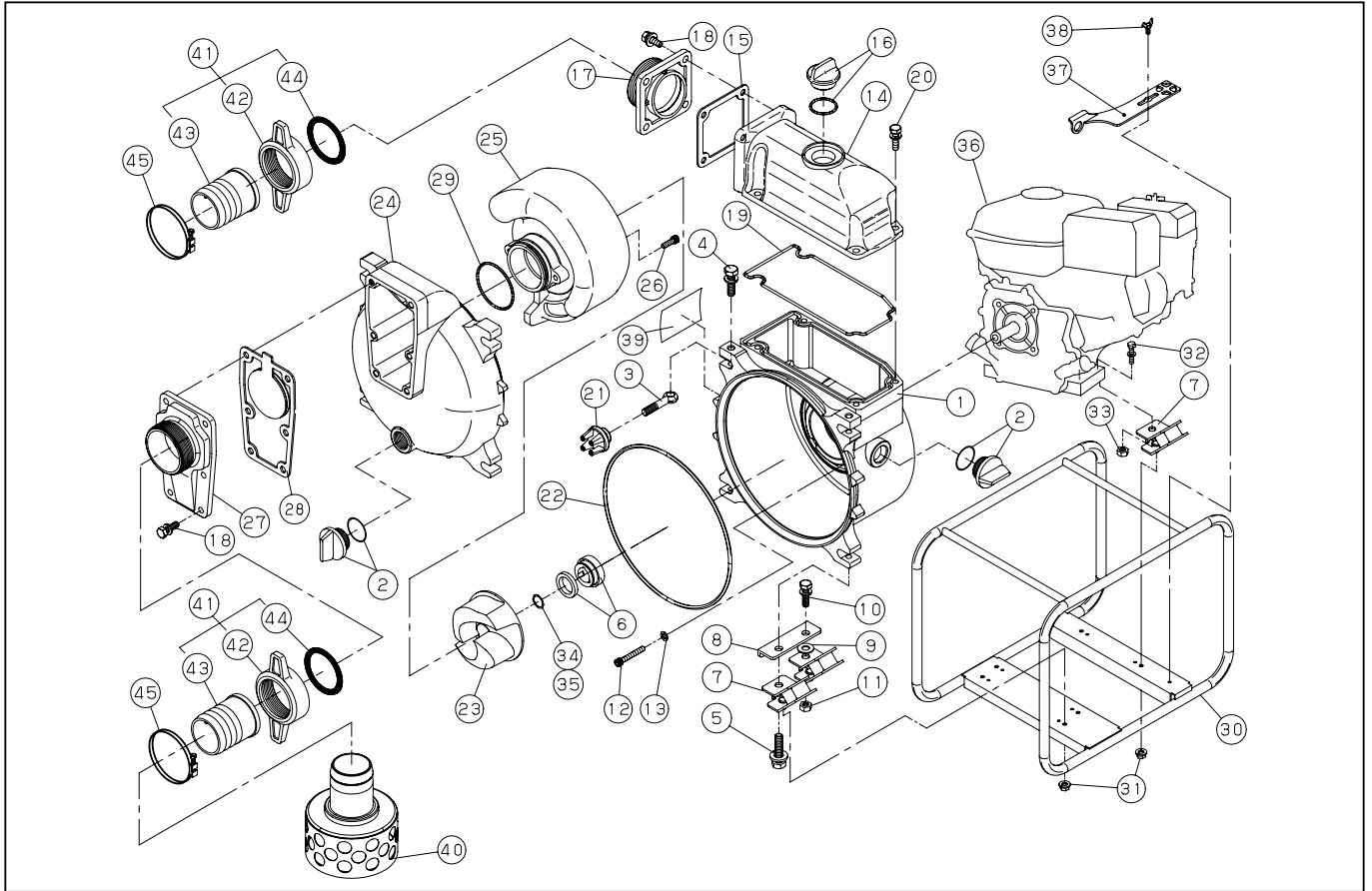

DWG No.012877804 MODEL : KTZ-100X FORM : KTZ-100X-BAF-0

| No. | PARTS CODE | PARTS NAME | QTY | MATERIAL | SIZE | REMARKS |
|-----|------------|---------------------------|-----|--------------|--------|---------|
| 31 | 842319008 | SPRING NUT | 6 | SWRM | M8 | |
| 32 | 743119067 | HEXAGON BOLT | 2 | SWRM | M10X40 | |
| 33 | 827419010 | HEXAGON NUT | 2 | SWRM | M10 | |
| 34 | 011056102 | ADJUSTING WASHER | 1 | BSP | | |
| 35 | 011640501 | ADJUSTING WASHER | 2 | BSP | | |
| 36 | 011447903 | HONDA ENGINE (WITH ALERT) | 1 | GX340 U1PKX2 | | |
| 37 | 011620401 | TOOL | 1 | SPC | | |
| 38 | 741305153 | WING BOLT | 1 | SUS | M8X15 | |
| 39 | 011661402 | NAME PLATE | 1 | | | |
| 40 | 011097903 | STRAINER | 1 | SPC | | |
| 41 | 011763901 | COUPLING SET | 2 | AC | | |
| 42 | 011618901 | COUPLING | 2 | AC | | |
| 43 | 011047103 | HOSE NIPPLE | 2 | AC | | |
| 44 | 011147801 | COUPLING PACKING | 2 | NBR | | |
| 45 | 940407120 | HOSE BAND | 3 | | | |
| | 011661501 | PACKING CASE | 1 | | | |
| | 011591103 | OPERATION MANUAL (E) | 1 | | | |
| | 011482009 | DECLARATION | 1 | | | |
| | 011471302 | CAUTION LABEL | 1 | | | |
| | 011471806 | CE MARK LABEL | 1 | | | |
| | 011641301 | EU NOISE LABEL | 1 | | | |

◆ Bare engine can not be supplied